

STREET

Property Lines

Existing House

PROPOSED
GARAGE

Proposed New
 $\text{---}' \times \text{---}'$
Private Garage

DRIVEWAY

SITE PLAN

**SAMPLE SITE PLAN FOR A
PRIVATE ONE STOREY GARAGE PLAN**

This sample is intended to assist the Applicant
in preparing their plan of Proposed Construction

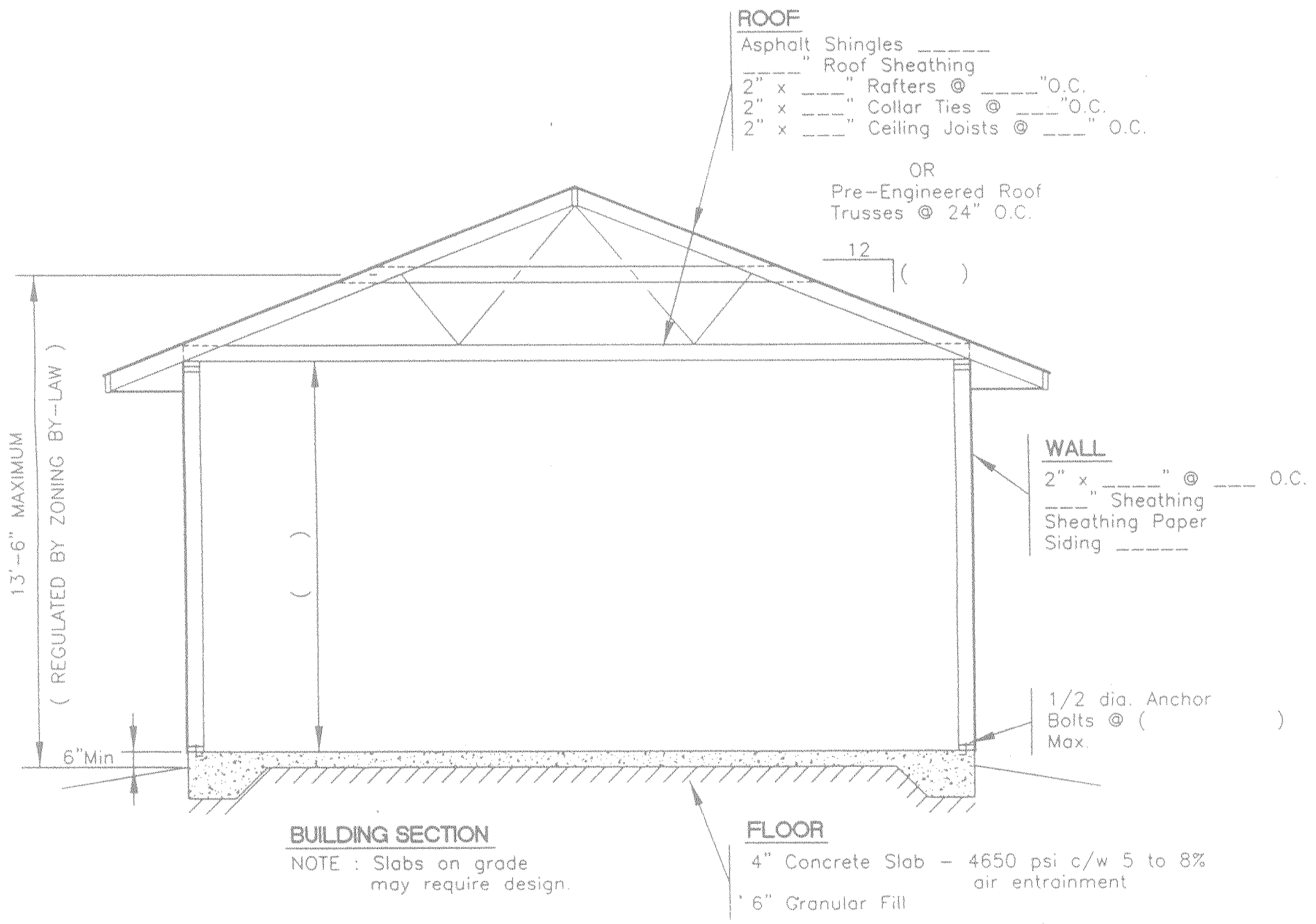

SAMPLE PRIVATE ONE STOREY GARAGE PLAN

This sample is intended to assist the Applicant
 in preparing their plan of Proposed Construction

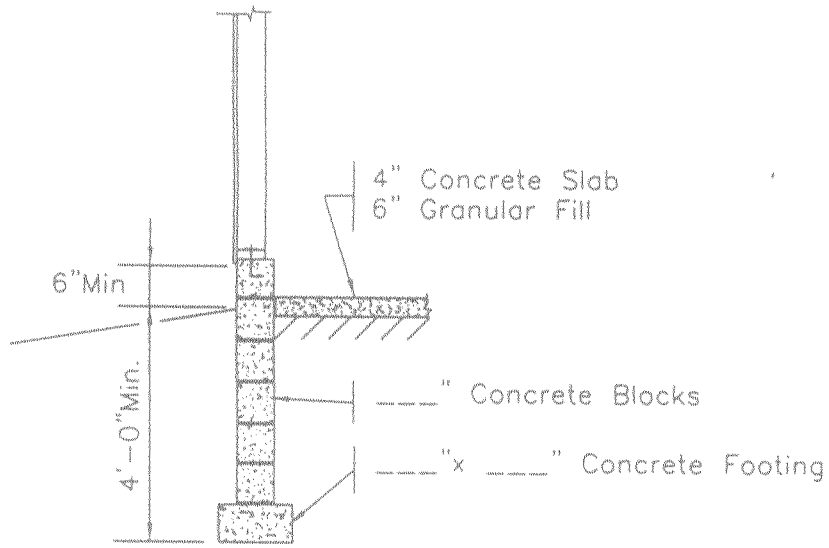

ALTERNATE FOUNDATION SYSTEM

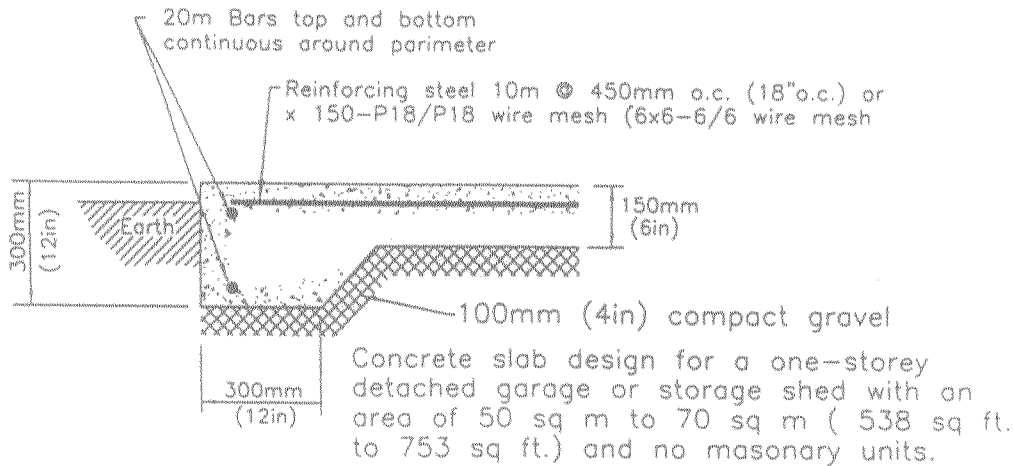

This slab design may be used depending on the soil condition information.

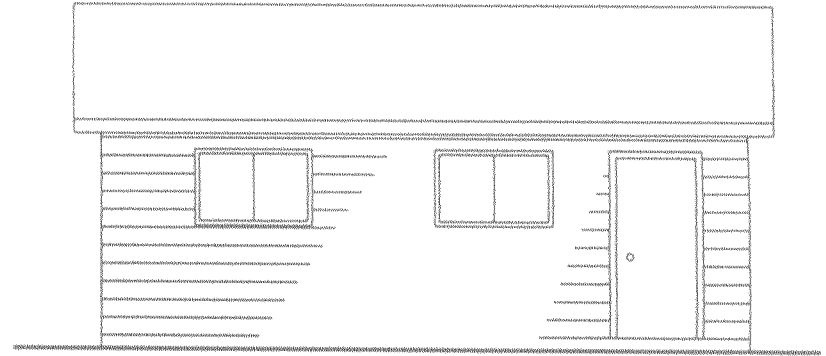

LEFT SIDE

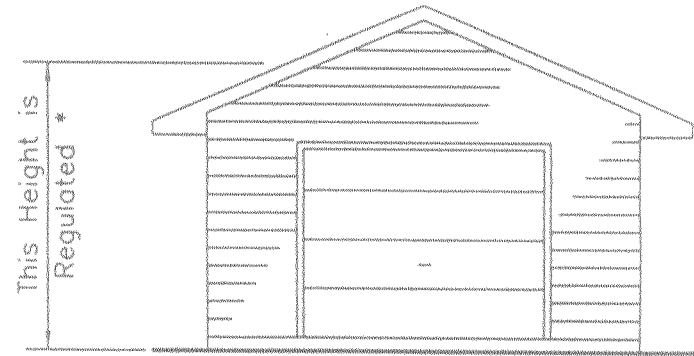

FRONT

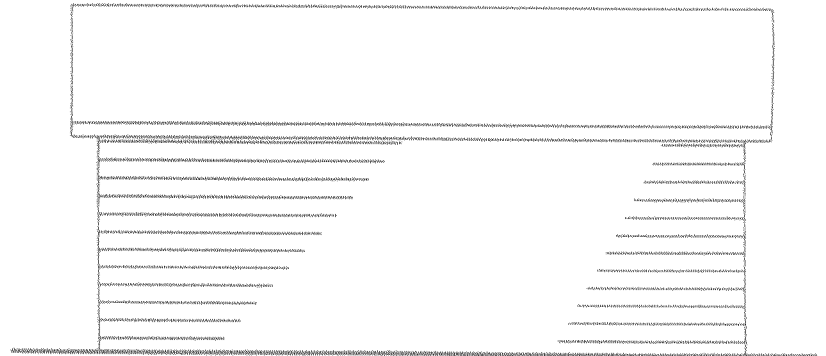

RIGHT SIDE

BUILDING ELEVATIONS

* NOTE :
For Max. Height of Building See Zoning Department.
Provide Location And Sizes Of All Openings In Walls.

SAMPLE PRIVATE ONE STOREY GARAGE PLAN

This sample is intended to assist the Applicant in preparing their plan of Proposed Construction